



# Integrity Instruments Incorporated

Phone 218-587-3175  
Fax 218-587-3414  
Web www.integrityusa.com

2642 20<sup>th</sup> Ave. S.W.  
P.O. Box 451  
Pine River, MN 56474

## Networking Topology (EIA/TIA/RS485)

According to ANSI/TIA/EIA-485-A:

*"The multipoint system should be configured in the form of a daisy chain. Star, tree, or branch configurations are generally not recommended"*

So what is daisy chain, star, tree, and branch network? As shown in figure 1, in a daisy chain network the wire is strung from the network origin to unit 1 then to unit 2 and continues in this "chain" fashion until reaching the end point. **This is the preferred method** because there is only one source of transmission line effect that needs to be addressed. This makes termination, grounding, and shielding reasonably straightforward. Termination is done at the opposite ends of the daisy chain. Normally this is a 120 ohm resistor between the A and B lines of the rs-485 data lines.

Repeaters can be added anywhere in the daisy chain to increase the total length run of your system.

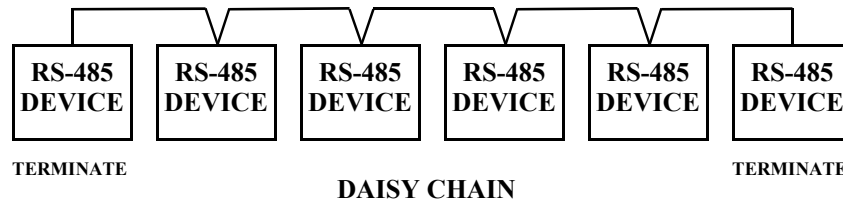

FIGURE 1

In the tree configuration shown in figure 2, the network wire is strung from the network origin to the network end point. Additional units are added by tapping off, also know as a stub, from the network backbone. This configuration is workable, however if the stub will be of considerable length you may consider inserting a repeater so that the stub may be properly terminated. Considerable length means cable runs long enough for transmission line effects to be an issue (see termination). This is close enough that a daisy chain should be used and you would avoid any potential issues that may arise by using this configuration.

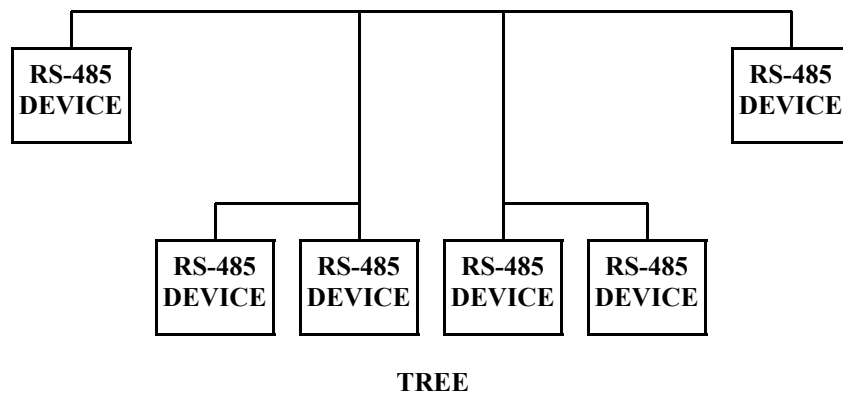

FIGURE 2

The star network shown in figure 3 is probably the worst configuratin that you can use. This is not to say that it cannot work, however it may require lots of magic fixit words and incantations. In any case, the star network is a scenario where there are multiple devices connected to a single point. The result of star network wiring is one generator driving into possibly many terminated nodes. The accumulated termination load will very quickly and load the network to an undesirable state making it unrealistic to expect reliable data communications. This is possible if there is only a few nodes or the network length is short enough that termination is not required. This is probably the worst configuration that you can use.

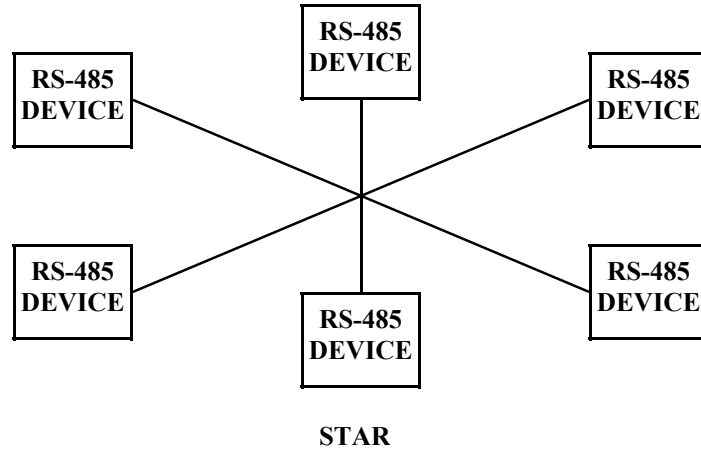

FIGURE 3

The branch network shown in figure 4 can start out looking very much like a daisy chain network, but somewhere along the line the network gets "stubbed" forming a tree or star configuration or combinations of the three. In doing so you needlessly increase load due to increased termination demands not to mention make a wiring nightmare.

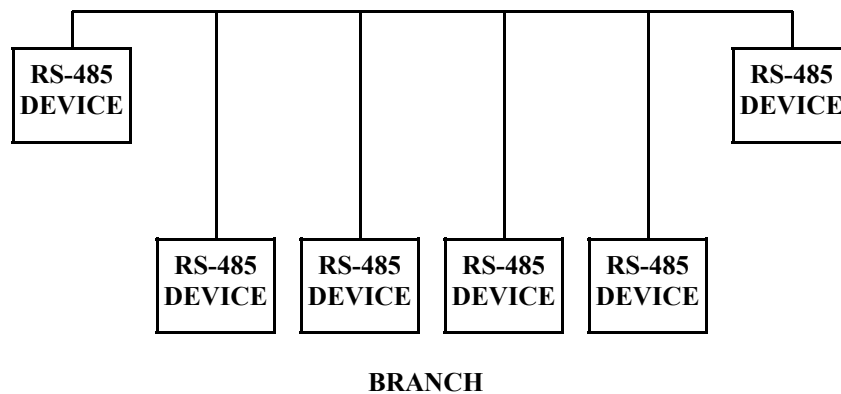

FIGURE 4

The goal of designing any network is to have reliable communications at a reasonable cost. Any of the above network topologies may be implemented and work well considering your budget is large enough for additional equipment such as repeaters. For example placing repeaters in a daisy chain configuration will allow you to branch off into additional daisy chain configuration with proper termination at all network end points.

## TERMINATION

Termination resistors on the rs-485 network are used to absorb the transmission-line signals so that it doesn't reflect off the end of the transmission line and then combine with subsequent data signals. The problem without termination resistors is that the signal reacts to the end of the transmission-line in much the same way that sound bounces off a flat surface. Even though the reflected signals have less power than the original signal, it still has the potential to combine with and thus tend to corrupt the ongoing data signals. The terminating resistor essentially makes the line look like it has infinite length, thus no flat surface to bounce off of. In this case the signal would look like it has an infinite length, and would propagate until its energy is completely dissipated

The far ends of the daisy chain should be terminated to prevent these signals from reflecting up and down the line. The termination resistance should match the characteristic impedance of the cable being used. Typically this is around 120 ohms. In addition Integrity Instruments devices have built in "active-passive" termination which greatly enhances the ability of the network to maintain data integrity.

## RS-485 CONNECTION

FIGURE 1 The "A" signals are daisy chained together, and the "B" signals are daisy chained together. Termination is shown at the far ends of the system.

FIGURE 2 Simplified version of FIGURE 1

FIGURE 3 Daisy chained system with a repeater.

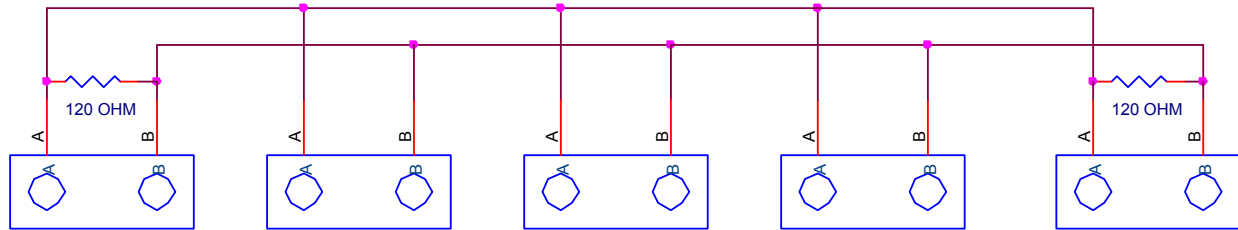

FIGURE 1

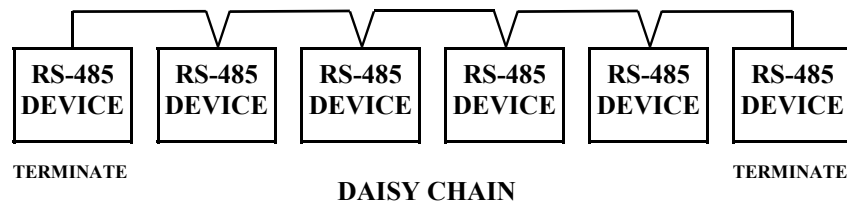

FIGURE 2

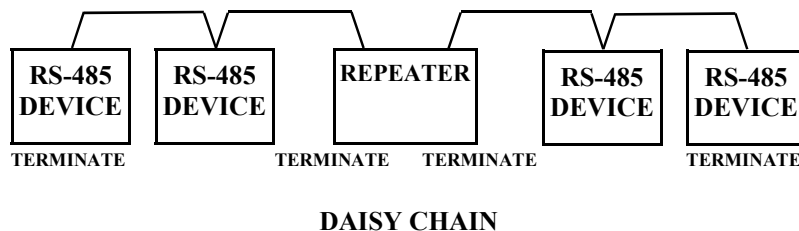

FIGURE 3