



Integrity Instruments

P.O. Box 451
Pine River Minnesota
56474 USA

Order Phone 800-450-2001
Fax Phone 218-587-3414
Tech Phone 218-587-3120

<http://www.integrityusa.com>

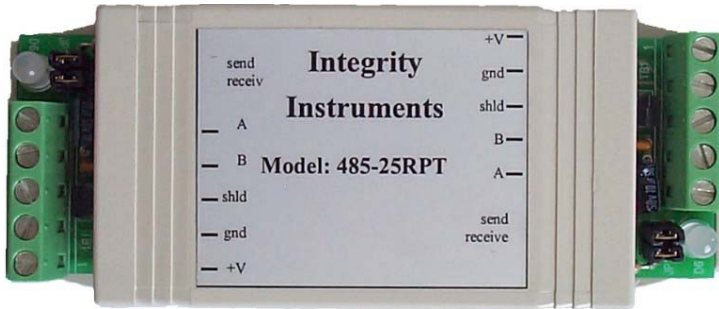

**485-RPT & 485-RPTL
High Speed**

**Auto Enabled
RS-485 Repeater**

Performance Characteristics

DC input voltage min. (+V)	7.5 Vdc
DC input voltage nominal. (+V)	12 Vdc
DC input current nominal (+V)	45 ma
DC input current max. (+V)	250 ma
ESD static discharge (A/B)	1500 V
Baud Rate maximum	115.2 Kbps
Baud Rate minimum	600 bps
Number of RS-485 nodes	256
Maximum cable length	4000 feet +
Termination resistance	120 ohms
MPU (4 Mhz)	PIC12C508
RS-485 line driver	LTC1487

POWER CONNECTION

The **485-RPT** requires an external power supply for proper operation. We suggest our PS9CST 9 Vdc 400 ma power supply.

Power can be connected to either side of the 485-RPT.

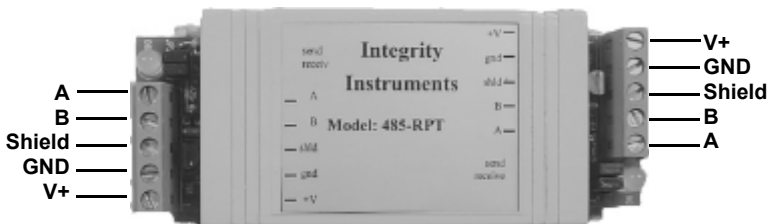

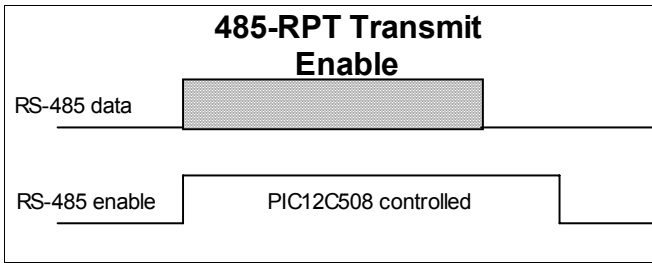

Auto Enable (Data Send Control)

The **485-RPT** automatically handles the RS-485 half-duplex control via an adaptive algorithm running in the on-board PIC12C508 MPU.

Normally both sides of the repeater are in a receive, or listening mode. When RS-485 data is received on one side, the opposite side RS-485 transmit enable is asserted immediately, and the data is then transmitted out of the opposite side.

After approximately one byte time of whatever baud rate is being used, (auto detected baud rate) of no RS-485 data being received, the transmit enable is turned off and the side is back to RS-485 receive.

The operation is identical in both directions.

Note: When using the **485-RPT** the responding RS-485 device must wait for the auto transmit enable to revert back to the receive state. If the responding RS-485 device transmits a packet back less than one byte time after the end of the packet, then there is Possibility of a data collision on the RS-485 interface.

LED Operation

The 485-RPT provides a bi-color signal LED to aid in cabling problems and general operation. Since this signal LED is powered only when data is present, it may be illuminated for somewhat brief periods. Also, if transmit and receive are closely spaced, the bi-colored LED may take on an orange hue when rapidly switching from RED to GREEN.

SIGNAL LED OFF:	No receive or transmitted data present
SIGNALLED RED:	RS-485 transmit
SIGNAL LED GREEN:	RS-485 receive

Dimensions

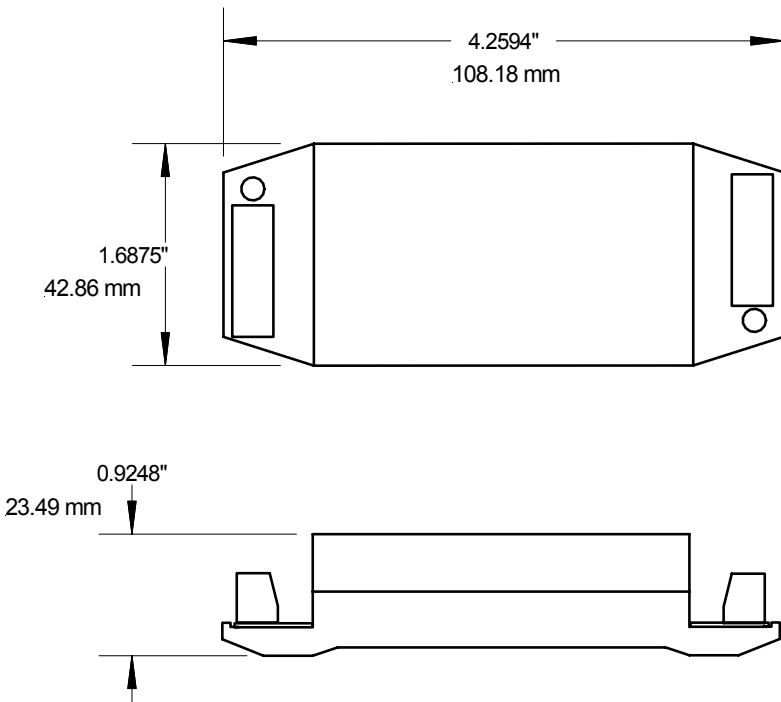

BUS Termination Jumpers

The **485-RPT** is manufactured with jumpers to enable and disable termination. The two RS-485 nodes at the extreme ends of the cable require termination.

Jumpers Installed: Installing JP1 and JP2 provides both active termination (R1/R2) and passive termination (R3) as seen in the schematic. *Active termination is important at its guarantees a stable RxD signal and no false start bits!*

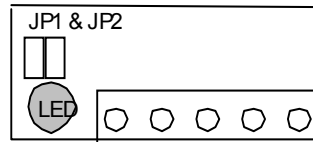
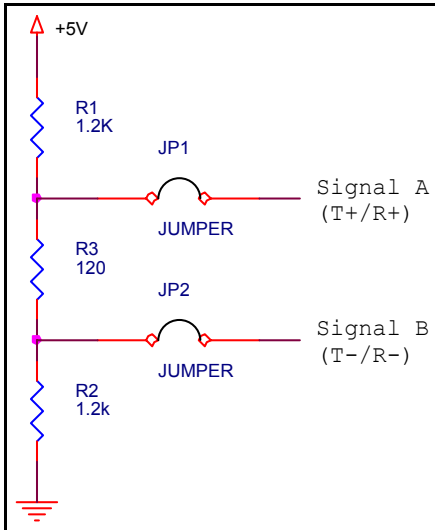

Jumpers Removed: No termination is provided at the converter.

NOTE: Ensure that only the two ends of the cable are terminated. Excessive termination will result in extreme line load and thereby adversely affect data transmission.

Cabling Notes:

- 1) Gnd and Shld are connected internally within the **485-RPT**
- 2) Cable termination is important for long distance and high-speed applications
- 3) **Suggested cable:** 24 awg stranded twisted pair with shield for cable runs in excess of 200 feet. See also Belden cable #9841 and #9463.
- 4) **Multiple power supplies:** Make sure that power supply +V outputs are **not** wired together.

RS-485 Cabling

The 485-RPT is designed to extend a Multi-Drop RS-485 LAN configuration 4000+ feet . In a half-duplex multi-drop environment all RS-485 nodes share the same data lines. A single pair of data lines act as both Transmit and Receive wires.

*** Data lines (A/B) are the only wires required between RS-485 nodes**

*** All RS-485 nodes need not share the same V+ and GND**

RS-485 Wire

Belden Cable Number	Number of pairs	DC Resistance ohms	Impedance ohms	Capacitance Pf per foot	Wire gauge	O.D. shield
9841	1	24 ohms/ 1000 ft	120	12.8	24(7x32)	.232 yes
9463	1	9.5 ohms/ 1000 ft	78	19.7	20(7x28)	.243 yes

Cabling Notes:

- 1) Gnd and Shld are connected internally within the **485-RPT**.
- 2) Cable termination is important for long distance and high-speed applications
- 3) Suggested cable: 24 awg stranded twisted pair with shield for cable runs in excess of 200 feet. See also Belden cable #9841 and #9463.
- 4) The normal connection method is the "Daisy Chain" type shown below. there are other kinds of connections, but this is considered as the standard.
- 5) The end units (**A**) and (**B**) should be terminated. All other units should not.
- 6) With the repeater in the middle of the daisy chain, you actually create two daisy chain networks with the repeater connecting the two daisy chains. Both ends of the two daisy chains created must be terminated, as shown below

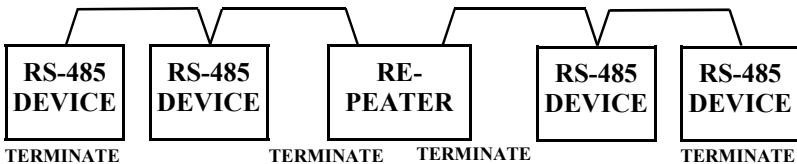
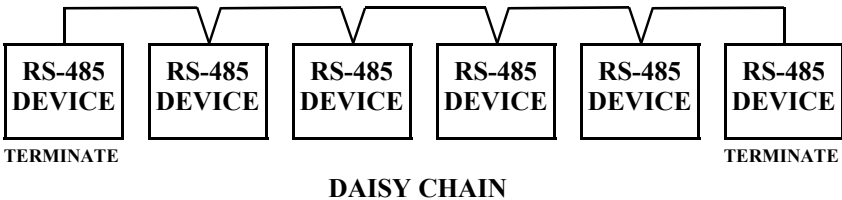

Notes

WARRANTY

Integrity Instruments warranties **all** products against defective workmanship and components for the life of the unit. Integrity Instruments agrees to repair or replace, at its sole discretion, a defective product if returned to Integrity Instruments with proof of purchase. Products that have been mis-used, improperly applied, or subject to adverse operating conditions fall beyond the realm of defective workmanship and are not covered by this warranty.

Copyright © 2000-2003, Integrity Instruments
All trademarks are property of their respective owners.
485_RPT